

FEATURES:

- High reliability, compact size
- Photoelectric isolation
- Input voltage range: 16V_{DC} to 40V_{DC}
- Output power: 20W~30W
- Inhibit function
- Short circuit protection
- DIP hermetical



DESCRIPTION:

The WKP28***-30 series module, which adopts Thick-Film Microcircuit Technology, stannic seam welding process, is a kind of perfect converter with high reliability necessary for some applications such as aviation, aerospace and military. The single output voltage is 3.3V, 5V, 12V, 15V; the dual output voltage is $\pm 12V$, $\pm 15V$. The output power is 20W~30W. The switching frequency is fixed at 265 KHz to minimize noise. The input filter circuit is designed to reduce the electro-magnetic interference. The typical input voltage is 28V, and the ranges from 16V to 40V. The WKP28***-30 series also provides some control functions such as shut down, and short circuit protection.

BLOCK DIAGRAM:

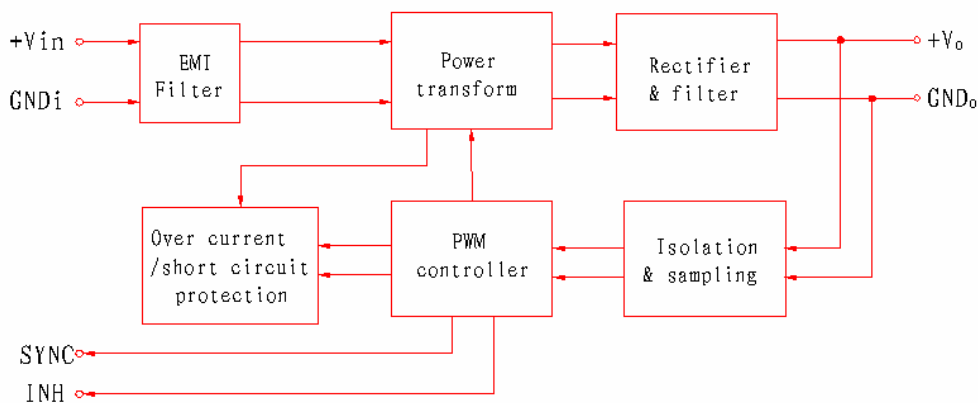

ABSOLUTE MAXIMUM RATINGS:

Output Power:	20W~30W
Operating Temp(T _c):	-40°C~85°C (E/I)
Storage Temp:	-55°C~125°C (E/I)
Pin-Solder Temp (10s):	300°C

THE ELECTRICAL CHARACTERISTICS:

SINGLE OUTPUT:

Parameter	Conditions ¹⁾	WKP283R3S-20			WKP2805S-25			WKP2812S-30			WKP2815S-30			Units
		MIN	TYP	MAX	MIN	TYP	MAX	MIN	TYP	MAX	MIN	TYP	MAX	
Output Voltage	V _{IN} =16V to 40V	3.27	3.30	3.33	4.95	5.00	5.05	11.88	12.00	12.12	14.85	15.00	15.15	V
Output Current	V _{IN} =28V _{DC}	0	—	6.06	0	—	5.0	0	—	2.5	0	—	2.0	A
Output Power	V _{IN} =28V _{DC}	0	—	20	0	—	25	0	—	30	0	—	30	W
Output Ripple Voltage ²⁾	20MHz	—	30	60	—	50	90	—	50	90	—	60	90	mV _{p-p}
	MIN~MAX T _C	—	—	90	—	—	90	—	50	120	—	60	120	
Line Regulation	V _{IN} =16V to 40V	—	10	20	—	10	30	—	40	80	—	60	90	mV
	MIN~MAX T _C	—	—	33	—	15	50	—	50	90	—	60	120	
Load Regulation	V _{IN} =28V _{DC}	—	10	20	—	10	30	—	40	80	—	60	90	mV
	MIN~MAX T _C	—	—	33	—	15	50	—	50	90	—	60	120	
Input Voltage	continuous	16	28	40	16	28	40	16	28	40	16	28	40	V
	50V/50ms	—	—	50	—	—	50	—	—	50	—	—	50	
Input Current	No load	—	30	85	—	35	75	—	35	75	—	35	75	mA
	Full load	—	0.94	—	—	1.17	—	—	1.30	—	—	1.25	—	A
	inhibit	—	3	8	—	3	8	—	3	8	—	3	8	mA
Input Ripple Current ³⁾	20MHz	—	25	50	—	25	50	—	25	50	—	25	50	mA _{p-p}
Efficiency	V _{IN} =28V _{DC}	72	76	—	72	76	—	80	83	—	80	84	—	%
Short Circuit	dissipation	—	—	15	—	15	—	—	15	—	—	15	—	W
	Recovery ⁴⁾	—	1.4	6	—	1.4	5	—	1.4	5	—	1.4	5	ms
Step Load Response Transient	V _{IN} =28V _{DC}	—	±125	±350	—	±200	±400	—	±250	±400	—	±350	±500	mV
Step Load Response Transient Recovery ⁴⁾	50%-100%-50%	—	—	200	—	60	200	—	60	200	—	60	200	μs
Step Line Response Transient	V _{IN} =16V to 40V	—	—	±300	—	±200	±300	—	±400	±500	—	±500	±600	mV
Step Line Response Transient Recovery ⁴⁾	Full load	—	—	300	—	—	300	—	—	300	—	—	300	μs
Start-Up	Delay	—	1.4	5	—	1.4	5	—	1.4	5	—	1.4	5	ms
	Overshoot (full)	—	0	50	—	0	100	—	0	120	—	0	150	mV _{pk}
	Overshoot (no)	—	33	150	—	50	350	—	120	600	—	150	750	
Insulation Resistance ⁵⁾	≥100MΩ@500VDC (input to output, any pins to case)													

NOTE:

- 1) Unless otherwise specified, Ta=25°C, Vin=28V_{DC}, 100% load.
- 2) Using tip and barrel measurement, by adding a 25v/1μF capacitor between Vo and outputs common.
- 3) Design guarantee.
- 4) To need times that Output voltage is renewed to 1% range of the stability value.
- 5) Only under the control of being machining for insulation resistance, each circuit should be assured to suffice need.

DUAL OUTPUT:

Parameter	Conditions ¹⁾		WKP2812D-30			WKP2815D-30			Units
			MIN	TYP	MAX	MIN	TYP	MAX	
Output Voltage	V _{IN} =16V to 40V	+Vo	11.88	12.00	12.12	14.85	15.00	15.15	V
		-Vo	11.82	12.00	12.18	14.77	15.00	15.23	
Output Current	V _{IN} =28V _{DC}	±I _o	0	-	1.25	0	-	1.0	A
Output Power	V _{IN} =28V _{DC}		0	-	30	0	-	30	W
Output Ripple Voltage ²⁾	V _{IN} =28V _{DC}		-	30	80	-	40	90	mV _{p-p}
	MIN~MAX T _C		-	40	120	-	40	120	
Line Regulation	V _{IN} =16V to 40V	+Vo	-	10	30	-	10	30	mV
		-Vo	-	50	120	-	50	150	
	MIN~MAX T _C	+Vo	-	10	50	-	10	50	
		-Vo	-	50	150	-	50	180	
Load Regulation	V _{IN} =28V _{DC}	+Vo	-	15	30	-	15	30	mV
		-Vo	-	30	120	-	30	150	
	MIN~MAX T _C	+Vo	-	15	50	-	15	50	
		-Vo	-	30	180	-	30	180	
Cross Regulation	20%~80% ³⁾	-Vo	-	4	8	-	3	8	%
	10%~50% ⁴⁾	-Vo	-	4	6	-	4	6	
Input voltage	Continuous		16	28	40	16	28	40	V
	50V/50ms		0	-	50	0	-	50	
Input current	No load		-	50	75	-	50	75	mA
	Full load		-	1.34	-	-	1.29	-	A
	Inhibit		-	3	8	-	3	8	mA
Input ripple current ⁵⁾	20MHz		-	20	50	-	20	50	mA _{p-p}
Efficiency	V _{IN} =28V _{DC}		78	81	-	80	83	-	%
Short Circuit	Dissipation		-	15	-	-	15	-	W
	Recovery time		-	1.4	5.0	-	1.4	5.0	ms
Step Load Response Transient	V _{IN} =28V _{DC}		-	±150	±400	-	±200	±400	mV
Step Load Response Transient Recovery ⁶⁾	50%~100%~50%		-	100	200	-	100	200	μs
Step Line Response Transient	V _{IN} =16V to 40V		-	±200	±400	-	±400	±500	mV
Step Line Response Transient Recovery ⁶⁾	Full load		-	-	300	-	-	300	μs
Start up	Delay		-	1.4	5	-	1.4	5	ms
	Overshoot (full)		-	0	120	-	0	150	mVpk
	Overshoot (no)		-	120	600	-	150	750	
Insulation Resistance ⁷⁾	≥100MΩ@500Vdc (input to output, any pins to case)								

NOTE:

- 1) Unless otherwise specified, Ta=25°C, Vin=28V_{DC}, 100% load.
- 2) Using tip and barrel measurement, by adding a 25v/1 μ F capacitor between Vo and outputs common.
- 3) -Pout 20%, +Pout 20%~80%。
- 4) -Pout 10%, +Pout 10%~50%。
- 5) Design guarantee.
- 6) To need times that Output voltage is renewed to 1% range of the stability value.
- 7) Only under the control of being machining for insulation resistance, each circuit should be assured to suffice need.

TYPICAL PERFORMANCE CURVES:

Single output (e.g. WKP2805S-25) :

1: Output Ripple Voltage

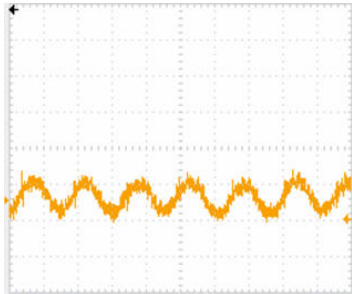

2: Start - Up

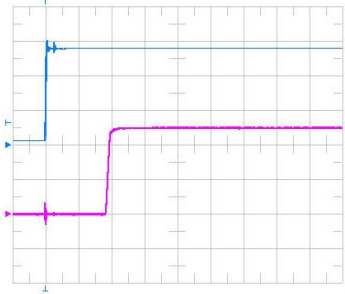

3: Step load Response

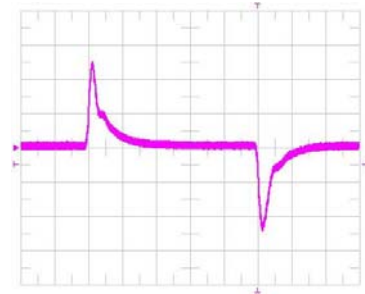

Dual output (e.g. WKP2815D-30) :

1: Output Ripple Voltage

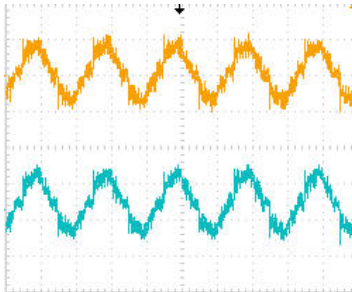

2: Start - Up

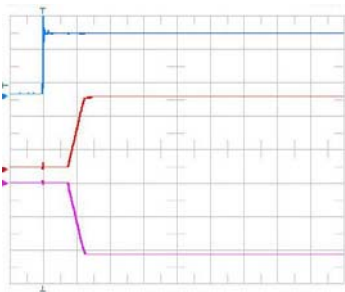

3: Step load Response

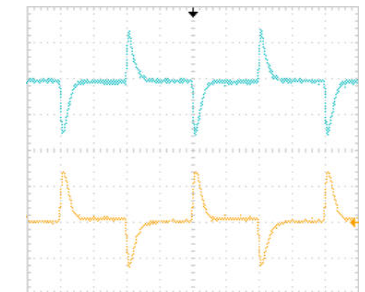

APPLICATION NOTE:

- DC-DC converter typical connection shown as below:

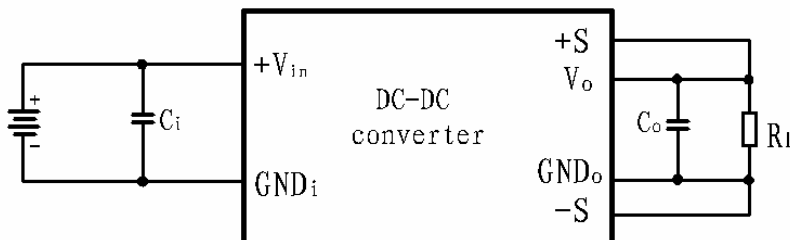

- **Inhibit Function**

The INH pin is used to control the on/off inhibit function. No connection to Pin 2 is necessary for normal operation of the converter. Shut down may be implemented by simply pulling the Pin 2 below 0.3V referenced to input common. The INH pin should be empty when not in use.

- **Over Current/Short Circuit Protection**

The WKP28***-30 series of DC-DC converters feature internal over current/short circuit protection. When it is operating under a load fault condition, the converter will automatically activate the over current/short circuit protection feature and restore the converter to normal operating conditions when the load fault is removed. It is suggested that the duration of the current/short must be less than 10s and the case temperature lower than T_{max}. Otherwise, the module will be disabled.

● Ripple Voltage Suppress

While the output V-ripple can't satisfy your application, it can still be suppressed by adding a filter capacitor between Vo+ and Vo-outputs. The optimal value for this capacitor is recommended at around 50V/ 10 μ F with film or ceramic capacitor as preferable options.

● Synchronization

The WKP28***-30 series of DC-DC converters allow the designers to match the switching frequency of the converter to the frequency of an external system clock or synchronize several modules by synchronization pin. Frequency ranges from 200 KHz to 350 KHz, the level from -0.3 to 10V, and duty cycle from 40% to 60%. Under master and slave configuration, the master module will deliver \pm 3mA current and the slave will deliver \pm 0.5mA in maximum. The sync pin should be empty when not in use.

● Remote Sensing

Remote sense allows the user to compensate for voltage drop between the output of the converter and the point of regulation. The total voltage which may be compensated for is 0.5v in both leads (+) and (-). Mark the connection to the regulation point within 1.2 meters of the converter output terminal.

● Reverse Polarity Protection

To avoid damage to the converter caused by reverse input connections, it's advised to connect a diode in series with the input pin of the converter. (Shown as below):

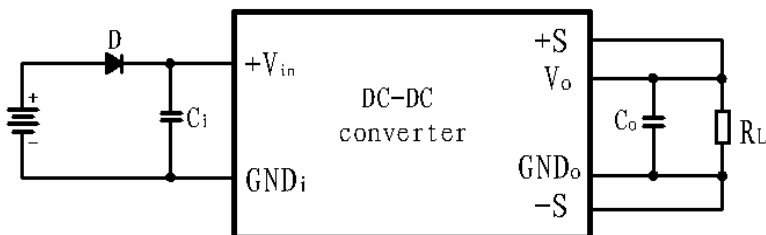

● Connection of Output in Series

Any of the bi output converters can be configured to produce an output of 24V (\pm 12V output models), or 30V (\pm 15V output models) by connecting the load across the output (+) and the output (-) with output ground, and leaving the common pin floating.

Notes:

1) Please properly connect pins of power module to PCB following instructions of part's specification.

2) To prevent pins of power module from being stressed to cause glass insulators cracked and power module leaked, please install power module with fixed flanges or screws prior to welding pins of power module.

3) The bottom of power module should be stressed to heat sink tightly. If necessary, thermal washers and shockproof gaskets are employed.

4) In any case, bending of pins should be avoided to keep glass insulators from cracking and prevent power module from leaking.

ENVIRONMENTAL SCREENING:

E:					
Num	TEST ITEMS		METHODS	REQUEST	CONDITIONS
1	Internal Visual		MIL-STD-883 Method 2017	100%	---
2	Temp-Cycle		MIL-STD-883 Method 1010	100%	-55°C to +125°C, 10 times
3	Constant Acceleration		MIL-STD-883 Method 2001	100%	500g, Y1, 1min
4	Burn-in		MIL-STD-883 Method 1015	100%	T _C : +85°C 96h
5	Final Electrical Test	Natural temperature	MIL-PRF-38534	100%	+25°C
		High temperature		100%	T _C : +85°C
		Low temperature		100%	-40°C
6	External Visual		MIL-STD-883 Method 2009	100%	---
I:					
Num	TEST ITEMS		METHODS	REQUEST	CONDITIONS
1	Internal Visual		MIL-STD-883 Method 2017	100%	---
2	Burn-in		MIL-STD-883 Method 1015	100%	T _C +85°C 48h
3	Final Electrical Test		MIL-PRF-38534	100%	+25°C
4	External Visual		MIL-STD-883 Method 2009	100%	---

Mechanical:

Volume: 18.6cm³ Weight: ≤53g Shell Material: Cold Rolled Steel

K form (e.g. WKP2815S-30I) :

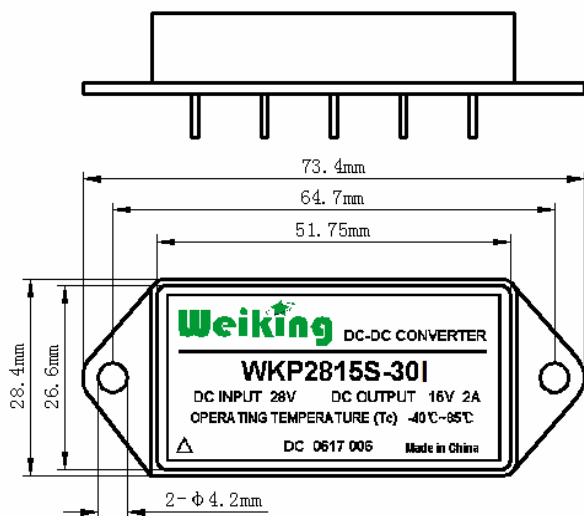

PIN FUNCTIONS

PIN	SINGLE		DUAL	
	FUNCTION	Symbol	FUNCTION	Symbol
1	POSITIVE INPUT	+Vin	POSITIVE INPUT	+Vin
2	INHIBIT	INH	INHIBIT	INH
3	SENSE RETURN	-S	POSITIVE OUTPUT	+Vo
4	OUTPUT COMMON	GND _o	OUTPUT COMMON	GND _o
5	POSITIVE OUTPUT	+Vo	NEGATIVE OUTPUT	-Vo
6	POSITIVE SENSE	+S	CASE GROUND	CASE
7	CASE GROUND	CASE	CASE GROUND	CASE
8	CASE GROUND	CASE	CASE GROUND	CASE
9	SYNC	SYNC	SYNC	SYNC
10	INPUT COMMON	GND _i	INPUT COMMON	GND _i

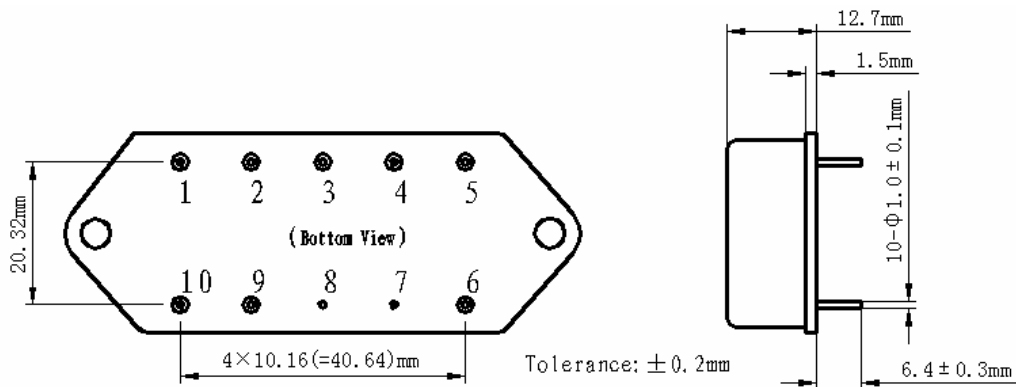

ORDERING INFORMATION:

WK P 28 15 S - 30 I

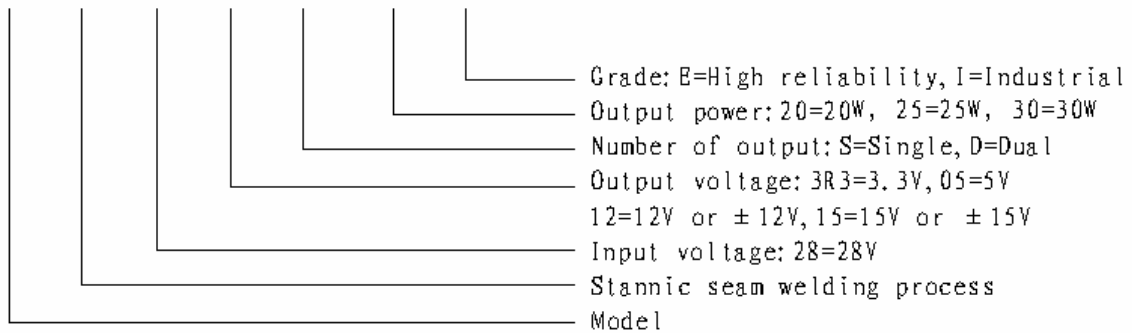

Mark specification:

Serial Number: DC 0617 006, example indicates this product has been manufactured in the 17th week of 2006, and the sequence number is 006.