

WK2030 Series switching regulator

FEATURES :

- Up to 93% efficiency for 5V version
- 3A Output current
- 4.5V to 32V Input range (2.5V output)
- 2.5V、3.3V、5.0V Fixed Output Versions
- 300KHz Switching frequency @1A and above
- User programmable soft-start
- Quiescent current less than 1mA
- User programmable current limit



DESCRIPTION :

WK2030 series are high efficiency step-down Switching regulators, which output current less than 3A and making them ideal for use in military, aerospace and other high reliability applications. WK2030 series uses thick-film hybrid techniques and are packaged in hermetically sealed metal cases. The output voltage is configured for 2.5V, 3.3V internally and the input range is 4.5V to 32V. The output voltage is configured for 5.0V internally and the input range is 6.5V to 32V. The operating frequency of the WK2030 is 300KHz and internally set. An external "soft start" capacitor allows the user to control how quickly the output comes up to regulation voltage after adding the input voltage. An extremely low quiescent current and high efficiency keep the total internal power dissipation of the WK2030 down to an absolute minimum.

ABSOLUTE MAXIMUM RATINGS:

V_{EN} Enable Voltage: 32V Tst Storage Temperature Range (M/E/I) : -55°C~+125°C
Sense pin voltage: 7V Tld Lead Temperature Range(10s): 300°C
Tc Operating Temperature: -55°C~+105°C (M) /-40°C~85°C (E/I)
Tj Junction Temperature: 150°C

THE ELECTRICAL CHARACTERISTICS:

Parameter	Test Condition ¹⁾	WK2030-2.5			WK2030-3.3			WK2030-5.0			Unit
		MIN	TYP	MAX	MIN	TYP	MAX	MIN	TYP	MAX	
Input voltage	full load	4.5	-	32	4.5	-	32	6.5	-	32	V
Output voltage	V _{IN} =V _{MIN} full load	2.45	2.50	2.55	3.25	3.30	3.35	4.90	5.00	5.10	V
Output current	V _{IN} =V _{MIN}	0	-	3000	0	-	3000	0	-	3000	mA
Line regulation	Input range all	-	10	50	-	10	50	-	10	50	mV
Load regulation	V _{IN} =V _{MIN} No load~ full load	-	10	50	-	10	60	-	10	100	mV
Efficiency	V _{IN} =V _{MIN} I ₀ =1A	85	-	-	90	-	-	93	-	-	%
Insulation resistance		≥100MΩ@500V _{DC} (input -case; output-case)									

Note:1) Unless otherwise specified, T_A=25°C, V_{IN} = 28V_{DC}, 100% load.

APPLICATION NOTE:

- Typical connection shown as below:

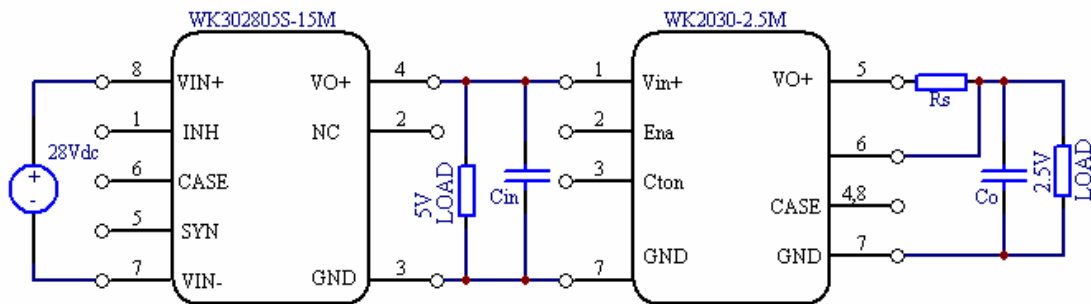

- Rs choice**

R_{SENSE}'s choice based on the requirement of output current. The current-limit circuit resets the main PWM latch and turns off the internal high-side MOSFET switch whenever the voltage exceeds Sense High and Sense Low 50mV. Allowing a margin for variations and external resistance values yields:

$$R_{SENSE} = \frac{50mV}{I_{max}}$$

For very high-current applications, it may be useful to wire the sense inputs with a twisted-pair instead of PCB traces. This twisted-pair needn't be anything unique, perhaps two pieces of wire-wrap wire twisted together. Low inductance current sense resistors, such as metal film surface mount styles are best.

- SOFT START**

The internal soft-start circuitry reduced input surge currents controlled this function by which put between PIN3 and GND. The value as follows:

$$T_{delay} = 15ms/\mu F \times (C_{ton} + 0.1)$$

No delay command, put 3pin noconnected.

● ENABLE FUNCTION

Enable pin 2 connect to GND, module no output.

● INPUT CAPACITORS SELECTION

To prevent large voltage transients, a low ESR input capacitor sized for the maximum RMS current must be used. RMS input ripple current is determined by the input voltage and load current, with the worst possible case occurring at VIN = 2 x VOUT, The maximum RMS capacitor current is

given by:
$$I_{rms}=I_{load} \times \frac{\sqrt{V_{out}(V_{in}-V_{out})}}{V_{in}} \quad V_{in}=2 \times V_{out}, I_{rms} \text{ max}$$

This makes it advisable to choose a capacitor rated at a higher temperature than required. Several capacitors may also be paralleled to meet size or height requirements in the design.

● OUTPUT CAPACITOR SELECTION

The selection of C_{OUT} is primarily determined by the effective series resistance (ESR) to minimize voltage ripple, The capacitor must meet minimum capacitance and maximum ESR values

as given in the following equations:
$$C_o \geq \frac{\Delta I}{8fs\Delta V_o} \quad ESR \leq \frac{\Delta V_o}{\Delta I_{load}}$$

ENVIRONMENTAL SCREENING:

M/E:						
Num	TEST ITEMS		METHODS	REQUEST	CONDITIONS	
1	Internal Visual		MIL-STD-883 Method 2017	100%	---	
2	Temp-Cycle		MIL-STD-883 Method 1010	100%	-55°C to +125°C, 10 times	
3	Constant Acceleration		MIL-STD-883 Method 2001	100%	3000g, Y1, 1min	
4	Burn-in		MIL-STD-883 Method 1015	100%	T _C :+105°C 160h (M)	
					T _C :+85°C 96h (E)	
5	Final Electrical Test	Natural temperature	-	100%	+25°C	
		High temperature			100%	T _C : +105°C(M) T _C : +85°C(E)
		Low temperature			100%	-55°C(M)/ -40°C(E)
6	Seal (Fine and Gross)		MIL-STD-883 Method 1014	100%	Fine Leak, Cond. A1	
					Gross Leak, Cond. C1	
7	External Visual		MIL-STD-883 Method 2009	100%	---	
I:						
Num	TEST ITEMS		METHODS	REQUEST	CONDITIONS	
1	Internal Visual		MIL-STD-883 Method 2017	100%	---	
2	Burn-in		MIL-STD-883 Method 1015	100%	T _C +85°C 48h	
3	Final Electrical Test		-	100%	+25°C	
4	External Visual		MIL-STD-883 Method 2009	100%	---	

DIMENSIONS & CONNECTIONS:

Volume: 8cm³ Weight: ≤25g Material: 10# Steel

E.g WK2030-3.3M:

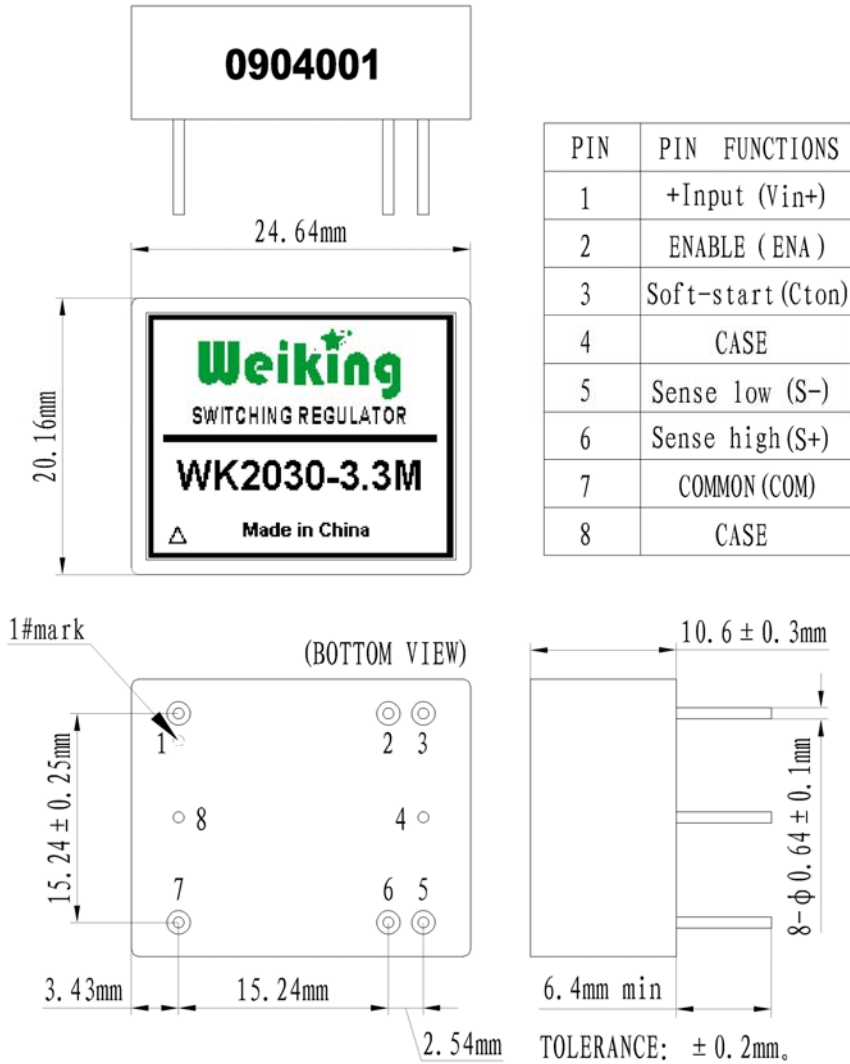

ORDERING INFORMATION:

MODEL NO SPECIFICATION:

WK 20 30 - 3.3 M

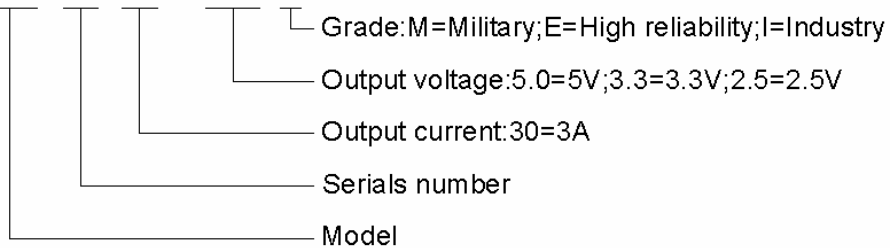

MARK SPECIFICATION:

Serials Number: 0904001, which indicates this product has been manufactured in the 4th week of 2009, and the sequence number is 001.